

**T.E. (Electrical) Sem. II Examination, 2009**  
**ELECTRICAL INSTALLATION MAINTENANCE AND TESTING**  
**(2003 Course)**

Time : 3 Hours

Marks : 100

- Instructions :**
- 1) Answer **any one** question from **each** Unit.
  - 2) Answers to the **two** Sections should be written in **separate** books.
  - 3) Neat diagrams must be drawn **wherever** necessary.
  - 4) Black figures to the **right** indicate full marks.
  - 5) Use of logarithmic tables, electronic pocket calculator is **allowed**.
  - 6) Assume suitable **data**, if necessary.

## SECTION – I

## Unit – I

1. a) State and prove Kelvin's law for feeder design with reference to supply system. State limitations of Kelvin's law. 8
- b) Compare 3-phase, 3 wire overhead system with 3-phase, 4 wire overhead on the basis of volume of conductor material. 8

OR

2. a) What are different types of feeder and distributor ? Explain relative advantages and disadvantages of them. 8
- b) A single phase ac distributor AB 300 meter long is fed from A is loaded for 100 A, 0.707 pf lagging 200 meter from point A and 200 A, 0.8 pf lagging 300 meters from point A. The load resistance and reactance of the distributor is  $0.2 \Omega$  and  $0.1 \Omega$  per km. Calculate the total voltage drop in the distributor. The load power factors refer to voltage the far end. 8

## Unit – II

3. a) Explain in detail soil resistivity and different factor which affect soil resistivity. 8
- b) Explain in detail procedure of design of earthing grid of a substation. 8

OR

P.T.O.



4. a) Define :
- a) Step potential
  - b) Touch potential
  - c) Transferred potential. **9**
- b) Draw duplicate busbar system used in substation. List various equipments used in it. **7**

### Unit – III

5. a) What are different insulation stressing factors ? Explain them in brief. **9**
- b) Explain the terms – Polarization index, dielectric absorption discharge. Explain their significance in condition monitoring. **9**

OR

6. a) What are different types of maintenance strategies ? Explain break down maintenance and planned maintenance. **10**
- b) Explain the concept of condition monitoring of electrical equipments. **8**

### SECTION – II

### Unit – IV

7. a) Explain with neat block diagram filtration of transformer insulating oil. **8**
- b) In connection with transformer condition monitoring explain following : **10**
- a) Dissolved gas analysis,
  - b) Degree of polymerization.

OR

8. a) Explain in detail various failure modes of transformer. **10**
- b) Write note on condition monitoring of On Load Tap Changer. **8**



**Unit – V**

9. a) Explain the various failure modes of power cables and list the various tests conducted on power cables. **8**
- b) Write detail note on thermography. **8**

OR

10. a) What are the various abnormal operating conditions in induction motor ? State their causes. **10**
- b) Explain the importance of  $\tan \delta$  and partial discharge in condition monitoring of electrical equipments. **6**

**Unit – VI**

11. a) Explain with neat figure and with example nomenclature of bearings. **8**
- b) Discuss in detail failures in bearings. **8**

OR

12. a) Explain condition monitoring of motors using spark pulse measurement method. **8**
- b) Write short note on :
- a) Tell Tale signs on bearings
- b) Vibration signature analysis.



**T.E. (Electrical) (Semester – II) Examination, 2009**  
**ELECTRICAL MACHINES – III**  
**(2003 Course)**

Time : 3 Hours

Max. Marks : 100

- Instructions :** 1) Answer **Q. 1 or Q. 2, Q. 3 or Q. 4, Q. 5 or Q. 6** from Section I.  
2) Answer **Q. 7 or Q. 8, Q. 9 or Q. 10, Q. 11 or Q. 12** from Section II.  
3) Answer to the **two** Sections should be written in **separate** books.  
4) **Neat** diagrams must be drawn **wherever** necessary.  
5) **Black** figures to the **right** indicate **full** marks.  
6) Use of electronic pocket calculator is **allowed**.  
7) Assume suitable data, if **necessary**.

SECTION – I

1. a) Explain pitch factor and distribution factor in case of a synchronous machine. **6**  
b) What is armature reaction of a three phase alternator ? How do you consider its effect in case of I) cylindrical rotor and II) projected pole rotor machines ? **6**  
c) Determine useful flux per pole of a turbo-alternator with sinusoidal flux distribution. It is a 3 phase, star connected, 50 Hz, 2 pole alternator having 54 slots with 4 conductors per slot. The coil pitch is 2 slots less than pole pitch. The machine generates 6.6 kV between lines on open circuit. **6**

OR

2. a) Draw the phasor diagram of a cylindrical rotor three phase alternator at leading p.f. load. Explain how to calculate induced emf from the phasor diagram. **6**  
b) Compare the mmf method and potier triangle method to determine the regulation of a three phase alternator. **6**  
c) A 3 phase alternator works at 0.8 p.f. lagging rated load. Find the voltage regulation of the alternator. It is rated at 10 kVA, 400 Volts, 50 Hz, star connected. A field current of 2 Amp. produced an armature current (per phase) of 30 A. On short circuit and an emf of 300.39 Volts (per phase) on open circuit. The d.c. resistance per phase is 0.417 ohms. Assume a.c. resistance 20% more than d.c. resistance. **6**

P.T.O.



3. a) The armature winding of a salient pole synchronous machine is represented by d-axis and q-axis synchronous reactances instead of a single reactance. Why ? Also draw and explain the phasor diagram of salient pole synchronous machine to calculate the induced emf at lagging p.f. load. **8**
- b) Explain with a neat diagram, the slip test to determine d-axis and q-axis reactances of a synchronous machine (salient pole). **8**

OR

4. a) What are the conditions to be satisfied for parallel operation of alternator with infinite bus bar ? Explain in each case, what happens if the condition is not satisfied. **8**
- b) What is infinite bus bar ?  
Two 3 phase alternators operate in parallel. The rating of one machine is 200 MW and that of the other is 400 MW. The droop characteristics of their governors are 4% and 5% respectively from no load to full load. Assuming no load frequency of 50 Hz, how would a load of 600 MW be shared between them ? **8**
5. a) Draw and explain the phasor diagram of a three phase synchronous motor while working as a synchronous condenser. Also explain the significance of torque angle with respect to load in a synchronous motor. **8**
- b) A 400 V, 3 phase star connected synchronous motor has an armature resistance of 0.2 ohms per phase and synchronous reactance of 2 ohms per phase. While driving certain load, it takes 25 amp. Calculate the back emf induced in the motor if it is working with i) 0.8 p.f. lagging and ii) 0.9 p.f. leading. **8**

OR

6. a) Explain the working of a synchronous induction motor, with a neat diagram. **8**
- b) What is a damper winding of a synchronous motor ? Explain its purpose. **4**
- c) Compare synchronous motor with induction motor. **4**



SECTION – II

7. a) Compare a linear induction motor with a ordinary 3 phase induction motor. **3**
- b) Explain edge and end effect of a linear induction motor. **5**
- c) Explain how starting torque is developed by a single phase hysteresis motor. Derive expressions for hysteresis and eddy current torques developed by the motor. **8**

OR

8. a) Describe the construction and operating principle of a permanent magnet stepper motor. **7**
- b) List the advantages of a brushless d.c. motor. **3**
- c) With the help of a circuit diagram and schematics briefly explain the working of a brushless d.c. motor. **6**
9. a) How slot or tooth harmonics are generated in the waveform of an alternator ? What problems are experienced due to these harmonics ? How will you eliminate these harmonics ? **10**
- b) A 3 phase, 4 pole induction motor has 48 stator and 52 rotor slots. Find the rotor speed at which harmonic synchronous torque would be developed. **6**

OR

10. a) What do you understand by harmonic synchronous torque and harmonic induction torque of a 3 phase induction motor ? Explain. **8**
- b) A 16 pole, 3 phase, star connected 50 Hz alternator has 144 slots. The coils are short pitched by 2 slots. The flux per pole is given by

$$\phi = 100 \sin \theta + 20 \sin 3 \theta + 15 \sin 5 \theta$$

Find the following :

- i) Percentage of 3<sup>rd</sup> harmonic in the phase and line voltage.
- ii) Fundamental component of phase emf if air gap flux (fundamental) is 0.06 wb per pole and the stator has 2 conductors per slot. **8**



11. a) Derive step by step the equivalent circuit of a 3 phase induction motor using the concepts of generalized machine theory. **8**
- b) A 10 kW, 415 V, 3 phase, 50 Hz slipping induction motor develops rated output as rated voltage and frequency. The maximum torque equal to 2.5 times the full load torque, occurs at a slip of 12% with zero external resistance in the rotor circuit. Stator resistance and rotational losses are neglected. Determine
- i) Slip and rotor speed as full load torque
  - ii) Full load torque. **5**
- c) Obtain identical transformations for currents from a rotating 3 phase (a, b, c) winding to a rotating balanced 2 phase ( $\alpha, \beta$ ) winding by changing both the magnitude of two phase currents and number of turns of the two phase windings. **5**

OR

12. a) Derive expressions for a 3 phase salient pole synchronous machine :
- i) armature to field mutual inductances. **3**
  - ii) armature self inductances. **7**
- b) A 2 pole, 3 phase, 50 Hz star connected cylindrical rotor alternator has synchronous inductance of 0.01 H per phase, negligible armature resistance, self inductance and resistance of field winding being 30 H and 20 ohm respectively. Mutual inductance between field winding and any one phase of armature winding, when their magnetic axes are aligned = 0.5 H. The alternator delivers power to a balanced load at unity p.f. Field winding is energised from 200 V d.c. source. If terminal voltage is 900 V per phase, find electrical power output of the generator. Also compute the excitation emf if the alternator delivers a line current of 200 A to a load at 0.8 p.f. lagging. **8**

**T.E. (Electrical) (Semester – II) Examination, 2009**  
**POWER ELECTRONICS**  
**(2003 Course)**

Time : 3 Hours

Max. Marks : 100

- Instructions :** 1) Answers to the **two** Sections should be written in **separate** books.  
 2) **Neat** diagrams must be drawn **wherever** necessary.  
 3) **Black** figures to the **right** indicate **full** marks.  
 4) **Use** of logarithmic tables, slide rule, Mollier charts, electronic pocket calculator and steam tables is **allowed**.

## SECTION – I

1. a) With neat circuit diagram explain class 'C' commutation. Draw waveforms. **10**  
 b) Explain working of TRIAC in four quadrant. Which quadrant is preferred for operation ? Why ? Draw VI characteristics. **6**

OR

2. a) What are different triggering methods of SCR ? Explain UJT oscillation triggering. **8**  
 b) Explain construction and working of SCR. Define latching and holding currents as applicable to an SCR. Show these currents on its static VI characteristics. **8**
3. a) What are the gate drive requirements of MOSFET and IGBT. **8**  
 b) Explain output and transfer characteristics of MOSFET and IGBT. **8**

OR

4. a) With the help of equivalent circuit of MCT explain turn on and turn off process in detail. State merits of MCT. **8**  
 b) Compare IGBT and BJT. **4**  
 c) State advantages and applications of IGBT. **4**

P.T.O.





5. a) With neat diagram explain working of single phase dual converter feeding RLE load in circulating current mode. Compare circulating current mode with non-circulating current mode. 10
- b) Explain with neat diagram single phase semiconverter feeding RL load. Draw output voltage and current waveforms. Compare semiconverter with full converter by drawing output voltage v/s firing angle. 8

OR

6. a) For the circuit shown in fig. Draw the output voltage and load current wave forms. Assume load is resistive. 6

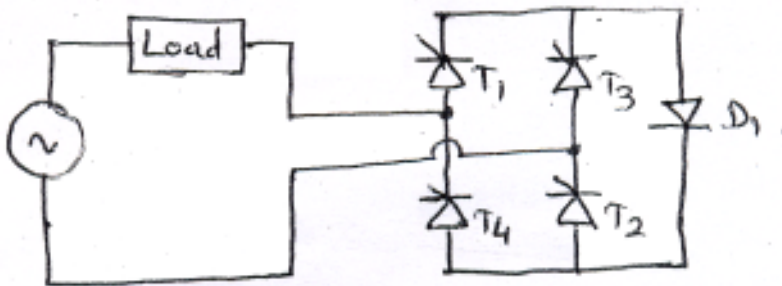

- b) Draw circuit diagram showing Asymmetrical configuration of single phase converter. Draw output voltage and current w/fs showing voltage across any one thyristor and mark clearly the device conducting during one cycle of input ac voltage for 'R' load. 6
- c) Draw circuit showing three phase semiconverter with R-L load and free wheeling diode for  $\alpha = \frac{\pi}{6}$ . Draw o/p voltage w/fs clearly showing device conducting during one cycle of input ac voltage. 6

SECTION – II

7. a) Explain the principle of step up chopper with the help of neat circuit diagram and derive expression for load voltage. 8
- b) What is ripple ? How switching frequency affects ripple content ? How device switching times affect the highest switching frequency ? 8

OR



8. a) Explain operation of class C chopper feeding a motor load, with help of neat circuit diagram for two quadrant operation of the motor. **8**
- b) Explain and compare TRC and CLC chopper with advantages and limitations. **8**
9. a) Draw single phase series inverter circuit and explain its working. What is type of commutation used ? What are applications ? **8**
- b) Explain working of single phase bridge inverter producing square wave voltage across the inductive load. Draw output voltage and current waveforms. What are the drawbacks of this circuit ? Why feedback diodes are used ? **8**

OR

10. a) Draw and explain 3 phase, six step voltage source inverter feeding star connected resistive load, in  $120^\circ$  mode of conduction. State clearly sequence of conduction. Draw control signals and waveforms for phase and line voltage across the load. **10**
- b) Explain why
- i) Power MOSFETS are best suitable switches for PWM inverter.
  - ii) What is shoot through fault ? How it can be avoided in bridge circuits ? **6**
11. a) Explain multiple PWM technique used in inverters. How voltage and frequency control is achieved ? What are advantages of PWM technique over other control strategies ? **9**
- b) What is snubber ? How power switching devices are protected using snubber ? What is its effect on individual power loss in switch ? **9**

OR

12. a) Explain sinusoidal PWM technique used in Inverters, with 5 pulses per half cycle of output voltage. What are amplitude and frequency modulation index ? How they affect the magnitude and frequency of output voltage ? How harmonics can be controlled using this technique ? **12**
- b) Explain various protections used in power electronic circuits. What is the importance of
- i)  $\frac{dv}{dt}$ ,  $\frac{di}{dt}$  ratings of device.
  - ii) Forward and reverse break over voltages.
  - iii) Maximum power, maxi temp and  $i^2t$  ratings. **6**



[3563] – 137

**T.E. (Electrical) (Semester – II) Examination, 2009  
MICROCONTROLLER AND ITS APPLICATIONS  
(2003 Course)**

Time : 3 Hours

Max. Marks : 100

- Instructions :** 1) Answer 3 questions from Section I and 3 questions from Section – II.  
2) Answers to the two Sections should be written in **separate books**.  
3) Neat diagrams must be drawn **wherever necessary**.  
4) **Black figures to the right indicate full marks**.  
5) **Use of logarithmic tables, slide rule, Mollier charts, electronic pocket calculator and steam tables is allowed.**

SECTION – 1

1. a) Explain the use of DPTR register in 8051. **4**
- b) Explain the internal RAM organization of 8051. **6**
- c) Write a program to find out 2's complement of a number stored at a location 39H. Store the result in location 3 AH. **6**

OR

2. a) Write a short note on all the bit addressable memory present in 8051. **4**
- b) Explain the Program Status Word in 8051. **6**
- c) Write a program to output 44H on Port 2, if bit P1.0 is set else output 55H on Port 2. **6**
3. a) Explain the difference between the MOVX and MOVC instructions. **4**
- b) Explain immediate addressing mode and direct addressing mode with suitable examples. **6**
- c) Assuming that XTAL = 11.0592 KHz. Write a program to generate a square wave of 2 KHz frequency on pin 1.5. **6**

OR

P.T.O.



4. a) Explain how variable baud rates can be generated for transferring and receiving data serially. **6**
- b) Write a program to enable all the interrupts and assign Timer 0 interrupt the highest priority. **6**
- c) Explain the functions of all the bits of SCON register. **4**
5. a) Using timer 1 in mode 1 write a subroutine which will generate a delay of 50 ms. Assume crystal frequency of 11.0592 Mhz. **6**
- b) Explain following instructions : **6**
- 1) DJNZ Rn, LABEL
  - 2) MOV C, 00H
  - 3) MOV 02H, 05H
- c) Write a program to test two numbers stored in location 40H and 41H. If the numbers are same load accumulator by 55 H else by 00H. **6**

OR

6. a) Discuss how switching of Register Banks is possible in 8051. Give a sequence of instructions to switch from Register Bank - 0 to Register Bank - 1. **6**
- b) 8 Kb of Program ROM and 8 Kb Data RAM is to be interfaced with 8051. Draw an diagram showing interfacing of these memories with 8051 such that following maps are realized. **6**
- Program ROM 0000H - 1FFFFH
- Data RAM 8000 H - 9 FFFH
- c) Explain the interrupt structure of 8051 with vector addresses. **6**



SECTION – 2

7. A) Explain steps to transfer data serially in 8051 and importance of T1 flag. **8**  
B) Write a short note on emulator, simulator, assembler and compiler used for 8051. **8**

OR

8. A) Explain salient features of members of MCS - 51 family. **8**  
B) Explain steps to receive data serially in 8051 and importance of RI flag. **8**

9. Write a short note on : **18**

(Assembly program is not expected)

- A) Humidity measurement using 8051.  
B) Temperature measurement using 8051.  
C) Pressure measurement using 8051.

OR

10. A) Draw and explain 8051 based stepper motor control interface diagram for two motors interfaced with Port 0 and Port 1. Write a program to rotate the two motors in opposite direction. **10**

- B) Explain 8051 based AC motor speed control method. **8**

11. A) Explain the features of MCS 96 family microcontrollers. **8**

- B) Write a short note on internal memory structure in 8096 family. **8**

OR

12. A) Draw the block diagram of 8096. **8**

- B) Explain the PWM output generation using 8096. **8**

**T.E. (Electrical) (Semester – II) Examination, 2009**  
**POWER SYSTEM – II**  
**(2003 Course)**

Time : 3 Hours

Max. Marks : 100

- Instructions.** : 1) Answer 3 questions from Section I and 3 questions from Section II.  
 2) Answers to the **two** Sections should be written in **separate** books.  
 3) Neat diagrams must be drawn **wherever** necessary.  
 4) **Black** figures to the **right** indicate **full** marks.  
 5) **Use** of logarithmic tables, slide rule, Mollier charts, electronic pocket calculator and steam tables is **allowed**.  
 6) Assume suitable data, if **necessary**.

## SECTION – I

1. a) Derive the expression for voltage and current relationship for long transmission line in terms A, B, C, D constants which are expressed in hyperbolic functions. **8**
- b) A 360 Km long single circuit three phase, 60 Hz transmission line has following constants.
- $r = 0.12 \Omega / \text{Km}$        $C = 0.009 \mu\text{F}/\text{Km}$   
 $L = 1.32 \text{mH}/\text{Km}$        $G = 0$
- The line is open at receiving end with voltage at that end as 132 KV  
 Find :
- i) Magnitude of incident and reflected voltage at 180 Km receiving end.  
 ii) Total line voltage at 180 Km from receiving end. **8**

OR

2. a) What are travelling waves ? Explain in detail. Derive the expressions for it. **8**
- b) A 400 Km long line has series impedance of  $0.62 \angle 75^\circ \Omega / \text{Km}$  and shunt admittance of  $2.85 \times 10^{-6} \angle 90^\circ \text{ S}/\text{km}$  phase to neutral.
- i) Find parameters at equivalent  $\pi$  circuit of the line  
 ii) Compare them with the parameters of nominal  $\pi$  circuit. **8**

P.T.O.



3. a) What do you understand by complex power ? Why the power is expressed considering complex conjugate of current ?

8

b) A, 12000 KVA, 12.5 KV, three phase alternator has a subtransient reactance of  $0.1 \Omega$ . It is connected through a  $\Delta - \Delta$  three phase, transformer to high voltage transmission line having total series reactance of  $150 \Omega$ . A load of 13.8 KV, 15000 KVA with reactance of  $j 0.526$  p.u. is connected at the end of line through  $\Delta - \Delta$  three phase transformer. Both transformers are rated 18 KVA, 13.8 KV/138 KV with the reactance of  $0.12 \Omega$ . Choose a base of 15000 KVA, 13.8 KV in load circuit. Draw reactance diagram and determine voltage at the terminals of generator Fig. 3 (b).

8

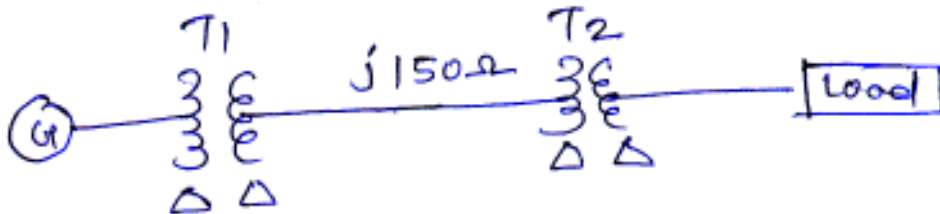

Fig. 3 (b).

OR

4. a) What is a concept of d.c. offset component in reference to short circuit fault current ? What is the effect of instant of fault occurrence on the waveform of short circuit current.

8

b) Two alternators are connected in parallel to a feeder through a three phase transformer Ratings at equipments are as follows :

Generator  $G_1$  : 50,000 KVA, 13.8 KV,  $X'' = 40\%$

Generator  $G_2$  : 40,000 KVA, 13.8 KV,  $X'' = 30\%$

Transformer : 70,000 KVA, 13.8 KV  $\Delta$ /138 KV  $\Delta$   $X = 10\%$

Before fault occurs voltage on H.T. side of transformer is 138 KV. The transformer is loaded and there is no circulation current between the alternators. Find subtransient current in each alternator, when a three phase short circuit occurs on H.T. side of transformer. Select a base of 70,000 KVA, 138 KV in H.T. circuit. Fig. 4 (b).

8

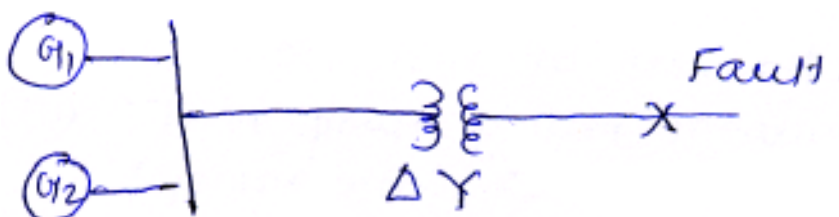

Fig. 4 (b).



- 5. a) What are the symmetrical components of voltage and current, which are considered for analysis of unsymmetrical fault ? 8
- b) Draw the equivalent circuit for zero sequence reactance of three phase transformer, for different combinations of connections. 10

OR

- 6. Write short note on : 18
  - i) Sequence reactance of transmission line and its expression.
  - ii) Sequence network diagram and its explanation for single line to ground fault.
  - iii) Three phase power measurement using symmetrical components.

SECTION – II

- 7. a) Write the general form of power flow equations for a  $n$ -bus power system and explain. 8
  - i) Nature and characteristics of equations.
  - ii) Practical constraints in load flow solution.
  - iii) Types of buses for load flow studies.
- b) Explain with suitable example, the method to write circuit equations of form  $[I]_{bus} = [Y]_{bus} \cdot [V]_{bus}$ . Explain the significance and nature of elements of  $[Y]_{bus}$  matrix. 8

OR

- 8. a) Compare between Gauss-Seidal and Newton-Raphson method to solve load flow equations. 8
- b) The parameters of a four-bus system are as under.

Bus code	Line Impedance (pu)
1 – 2	$0.2 + j 0.8$
2 – 3	$0.3 + j 0.9$
2 – 4	$0.25 + j 1$
3 – 4	$0.2 + j 0.8$
1 – 3	$0.1 + j 0.4$





The charging admittances are

$$y_{10} = j 0.03 \text{ pu}$$

$$y_{20} = j 0.09 \text{ pu}$$

$$y_{30} = j 0.06 \text{ pu}$$

$$y_{40} = j 0.06 \text{ pu}$$

Find bus admittance matrix.

**8**

9. a) Derive swing equation for a synchronous machine from fundamentals.

**8**

b) A 50 Hz four pole generator rated 20 MVA, 13.2 KV has an inertia constant of  $H = 9 \text{ kW-sec/KVA}$ . Determine the kinetic energy stored in the rotor at synchronous speed. Determine the acceleration if the input loss the rotational losses is 25000 HP and the electric power developed is 15000 kW. If the acceleration computed for the generator is constant for a period of 15 cycles, determine the change in torque angle in that period and the rpm at the end of 15 cycles. Assume that the generator is synchronized with a large system.

**8**

OR

10. a) Derive power angle equation for one machine connected to an infinite bus. Also draw power angle curve.

**8**

b) Define steady state and transient stability. Discuss different factor affecting stability of a power system.

**8**

11. a) Discuss advantages and disadvantages associated with HVDC transmission system.

**8**

b) What are the recent developments in HVDC transmission system ? Discuss future scope of HVDC transmission systems in India.

**10**

OR

12. a) With the help of suitable diagram, explain different components of a HVDC transmission system along with their functions.

**10**

b) Explain constant current control method for HVDC transmission system.

**8**



[3563] – 135

**T.E. (Electrical Engineering) (Semester – I) Examination, 2009**  
**MANAGEMENT TECHNIQUES**  
**(2003 Course)**

Time : 3 Hours

Max. Marks : 100

- Instructions :** 1) Answer *any one* question from *each* Unit.  
2) Answers to the *two* Sections should be written in *separate* books.  
3) *Neat* diagrams must be drawn *wherever* necessary.  
4) *Black figures* to the *right* indicate *full* marks.  
5) Assume *suitable* data, if *necessary*.

**SECTION – I**

**Unit – I**

1. a) Define engineering economics. Discuss the need, use and scope of engineering economics. **10**  
b) State and explain the law of diminishing utility. **6**

**OR**

2. a) What is meant by Joint Stock Company ? Explain the procedure for forming a joint stock company. **10**  
b) Define Management. What are the principles of scientific management ? **6**

**Unit – II**

3. a) What are the major classes of material handling equipment ? Explain any two material handling equipment used in automated manufacturing environment. **10**  
b) Distinguish between a 'bid' and a 'tender'. What are the different types of tenders ? Explain. **8**

**OR**

4. a) What do you understand by Inventory ? Explain various ways of controlling inventory. **8**  
b) Define Plant Layout. Explain the following types of plant layout :  
i) Product Layout **10**                      ii) Cellular Layout

**P.T.O.**





10. a) What is a Kanban Card ? What are its types ? Explain its role in JIT manufacturing environment. **10**
- b) What are the qualities and functions of an entrepreneur ? **8**

**Unit – VI**

11. a) What is 'self development' ? Explain in brief different methods of self development. **8**
- b) Distinguish between Ethics and Morale ? Explain its role in the development of a good professional. **8**

OR

12. a) Define 'Communication'. Explain the process of communication with a neat line diagram. What are the advantages and disadvantages of Verbal and Nonverbal communication ? **16**

-----



**T.E. (Electrical) (Semester – I) Examination, 2009**  
**CONTROL SYSTEM – I**  
**(2003 Course)**

Time : 4 Hours

Max. Marks : 100

SECTION – I

1. a) With reference to closed loop control system, define the following terms :
- i) Command input
  - ii) Reference input
  - iii) Forward path
  - iv) Feedback path
  - v) Error signal.

What is the advantage of negative feedback over positive feedback ? 8

- b) A typical control system is described by the differential equation :

$$\frac{d^2 y(t)}{dt^2} + 7 \frac{dy(t)}{dt} + 20y(t) = x(t)$$

where  $y(t)$  : output and  $x(t)$  : input. Obtain the transfer function of the system.  
What is type and order of system ? 5

- c) The unit impulse response of a system is  $6 e^{-2t}$ . Find its transfer function. 3

OR

2. a) Using method of reduction, determine the ratio  $\frac{C(s)}{R(s)}$  in the block diagram as shown in fig. 2(a).

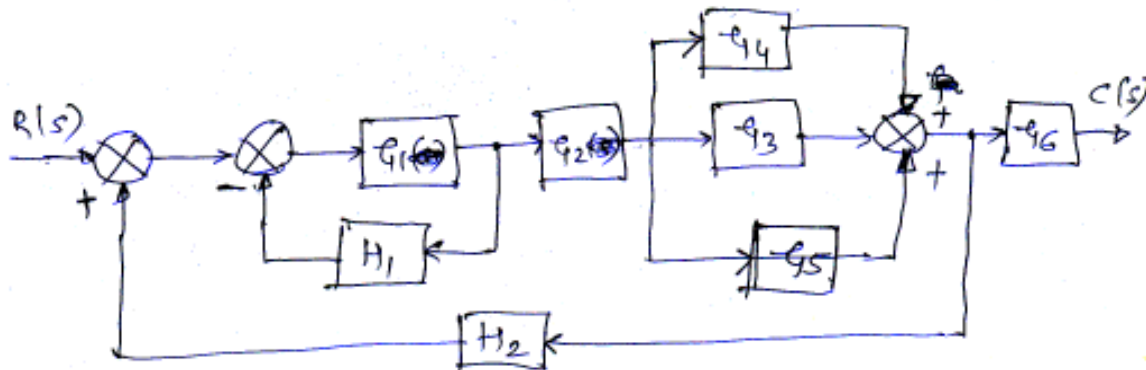
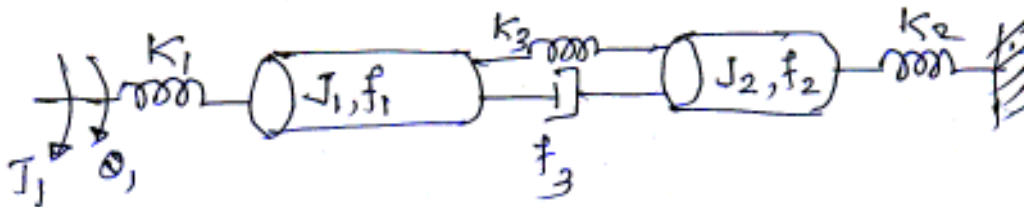

Fig. 2(a)



- b) Find the transfer function  $\frac{Q_1(s)}{T(s)}$  for the given rotational mechanical system as shown in fig. 2(b).



8

Fig. 2(b)

3. a) Find the time response, initial value and final values of the following function :

6

$$F(s) = \frac{s(s+10)}{(s+2)(s+4)(s+6)}$$

- b) Define the following systems, sketching their output waveform for a unit step input :

- i) Under damped system
- ii) Undamped system.

Give the range of damping ration for both types.

4

- c) The open-loop transfer function of a control system with unity feedback is

$$G(s) = \frac{150}{s(1+0.25s)}$$

- i) Evaluate the error series of the system.
- ii) Determine the steady state error for an input  $r(t) = (1 + t^2) u(t)$ .

6

OR

4. a) Write short notes on effect of PID controllers on performance of second order control system. What are controller constants and what is their role in design ?

8

- b) The block diagram of a position control system with velocity feedback is shown in fig 4(b). Determine the value of  $\alpha$  so that the step response has maximum overshoot of 10 percent. What is the steady state error ?

8

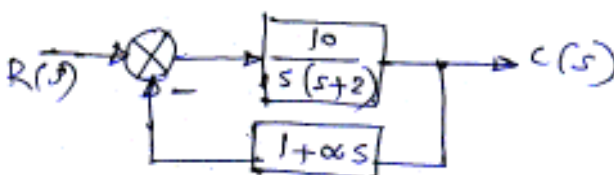

Fig. 4(b)



5. a) Explain the terms related to system stability :
- i) Absolute stable system.
  - ii) Marginally stable system
  - iii) Conditionally stable system
  - iv) Unstable system. 6
- b) Discuss Routh-Hurwitz criterion used to find system stability. What are the limitations of this criterion ? 6
- c) The open loop transfer function of a system is given by

where K is an adjustable loop gain. Find the range of values of K for which the system is stable. 6

OR

6. a) Explain the rules for sketching root-locus and finding stability of a closed loop system. 6
- b) Sketch the root locus for a given unity feedback control system whose open loop transfer function is  $G(s)H(s) = \frac{K}{s(s^2 + 2s + 2)}$

G(s) H(s) =  $\frac{K}{s(s^2 + 2s + 2)}$

Determine stability of the system. 12

SECTION – II

7. a) Write short notes on advantages and limitations of frequency response analysis. 4
- b) Derive an expression for the peak magnitude and the resonant frequency of a second order system. 8
- c) Discuss the relationship between time response and frequency response. 4

OR

8. a) Explain the terms :
- i) Gain cross over-frequency
  - ii) Phase cross over-frequency
  - iii) GM
  - iv) P.M. 6



- b) Sketch the bode plot and determine the following : **10**
- i) Gain cross-over frequency
  - ii) Phase cross-over frequency
  - iii) Gain Margin
  - iv) Phase Margin.

for the transfer function 
$$G(s) = \frac{10}{s(1 + 0.4s)(1 + 0.1s)}$$

9. a) What is a polar plot ? How polar plots are useful in finding stability of a control system ? **4**
- b) Sketch the polar plot of a type '0' system and add a pole to the transfer function, again sketch polar plot. What is its effect on polar plot ? **6**
- c) Write the short notes on N-circles and M-circles. **6**

OR

10. a) State and explain Nyquist stability criterion. **4**
- b) A unity feedback control system has an open loop transfer function given by

$$G(s)H(s) = \frac{100}{s(s+5)(s+2)}$$

Draw Nyquist diagram and determine stability. **12**

11. a) What is compensation network in control system design ? Sketch the different types of compensation networks. **8**
- b) Explain Lead compensation network design using i) Bode sketch  
ii) Root locus sketch. **10**

OR

12. Find the suitable compensator, by using root locus method, for the unity feedback system, whose open loop transfer function is  $G(s) = \frac{45}{s(s+3)}$  So that the damping ratio will be 0.5 and the undamped natural frequency will be 4 rad/sec. **18**





[3563] – 133

**T.E. (Electrical Engineering) (Semester – I) Examination, 2009**  
**DESIGN OF ELECTRICAL MACHINES**  
**(2003 Course)**

Time : 3 Hours

Max. Marks : 100

- Instructions :** 1) Answer **any three** questions from **each** Section.  
2) Answers to the **two** Sections should be written in **separate** books.  
3) **Neat** diagrams must be drawn **wherever** necessary.  
4) Black figures to the **right** indicate **full** marks.  
5) **Use** of logarithmic tables, slide rule, Mollier charts, electronic pocket calculator and steam tables is **allowed**.  
6) Assume suitable data, **if necessary**.

**SECTION – I**

1. a) With reference to the selection of electrical conducting materials for transformer compare characteristics of copper and aluminium on the basis of following :
- i) Density
  - ii) Melting point
  - iii) Thermal conductivity
  - iv) Resistivity
  - v) Resistance temperature coefficient at 20°C
  - vi) Coefficient of thermal expansion at 20°C. **12**
- b) Write a short note on Electrical sheet steel. **4**

**OR**

2. a) With reference to the heating and cooling cycles, explain the following terms:
- i) Heating time constant.
  - ii) Cooling time constant
  - iii) Maximum temperature rise and their estimation. **12**
- b) Write a shortnote on Insulating materials used for oil cooled transformers. **4**

**P.T.O.**



3. a) Write a shortnote on Specification of transformers as per IS 2026. **8**  
 b) Derive output equation of three phase transformer. **8**

OR

4. a) Draw neat sketches and discuss the special features of following windings used for 3- phase transformer : **9**  
 i) Cylindrical winding  
 ii) Helical winding  
 iii) Crossover winding  
 b) Draw neat sketches of mitred joints used for cores of cold rolled oriented steel and discuss following joints commonly used for core of 3 – phase transformer : **3**  
 i) 45° mitre joint. **4**  
 ii) 35°/55° mitre joint.

5. a) Estimate the per unit regulation at full load and 0.8 power factor lagging for 300 KVA, 50Hz, 6600/400 V, 3 phase, delta/star, core type transformer. The data given is

H.V. Winding :

Outside diameter = 0.36 m ; Inside diameter = 0.29 m ; Area of conductor = 5.4 mm<sup>2</sup>.

L.V. Winding :

Outside diameter = 0.26 m; Inside diameter = 0.22 m; Area of conductor = 170 mm<sup>2</sup>, Length of coils = 0.5 m; Voltage per turn = 8 Volts and Resistivity = 0.21ohm/m/mm<sup>2</sup>. **12**

- b) With reference to mechanical forces developed under short circuit conditions in transformer draw neat sketches of **6**  
 i) Leakage field.  
 ii) Axial leakage field and mechanical forces.  
 iii) Radial leakage field and mechanical forces and also discuss measure to overcome these effects.

OR



6. Write short notes on :

- a) Evaluation of no load current of 3 – Phase transformer.
- b) Design of cooling tanks of 3 – Phase transformer.
- c) Various methods used for cooling of 3– Phase transformer. **18**

SECTION – II

- 7. a) Derive the output equation of 3 – Phase induction motor. **7**
- b) Determine the main dimensions, number of stator slots and number of conductors for a 11 KW, 400 V, 3 phase, 50 Hz, 4 pole, 1425 RPM, delta connected induction motor. Assume specific magnetic loading of  $0.45 \text{ Wb/m}^2$ , specific electrical loading of 23000 A/m, full load efficiency as 0.85 and full load power factor as 0.88. Take ratio of core length and core pitch as 1. Stator employs a double layer winding. **9**

OR

- 8. a) Discuss various factors considered for choice of specific magnetic loading of 3 – phase induction motor. **9**
- b) Find the main dimensions of a 3 – phase, 10 KW, 400 V, 50 Hz, 4 pole squirrel cage induction motor. Assume full load efficiency = 0.85; Full load power factor = 0.86, Specific magnetic loading =  $0.4 \text{ Wb/m}^2$ ; Specific electrical loading = 20000 Amp/m ; Winding factor = 0.955 and stacking factor = 0.9 ; Take rotor peripheral speed as 20 m/sec. **7**
- 9. a) Discuss various constraints in the selection of suitable combination of stator and rotor slots. **6**
- b) Explain in detail the harmonic induction torque and harmonic synchronous torque in 3 – phase induction motor. **10**

OR



10. a) Which factors are considered in selection of length of air gap in 3 – phase induction motor ? **10**
- b) 11.2 KW, 415 V, 3 phase, 6 pole, 50 Hz, star connected squirrel cage induction motor has following data : Number of stator slots = 54; Number of rotor slots = 63; Number of conductors per slot = 16; full load efficiency = 0.87; Full load power factor = 0.82; Current density in rotor bars and end rings  $6 \text{ A/mm}^2$  and  $7 \text{ A/mm}^2$  respectively. Calculate the bar current and end ring current and cross section of bar and end ring. **6**
11. a) Explain the method of calculation of magnetization current of 3 – phase induction motor. **10**
- b) Write a shortnote on Leakage fluxes and leakage reactances in an induction motor. **8**

OR

12. a) Explain the method of Calculation of loss component of no load current of 3 – phase induction motor. **8**
- b) How performance of 3– phase induction motor can be estimated using circle diagram ? **10**

-----



[3563] – 132

**T.E. (Electrical) (Sem. – I) Examination, 2009**  
**ELECTRICAL MACHINES – II**  
**(2003 Course)**

Time : 3 Hours

Max. Marks : 100

- Instructions** : 1) Answers to **two** Sections must be written in **separate** answer books.
- 2) From Section – I attempt Q. No. 1 or 2, Q. No. 3 or 4 and Q. No. 5 or 6.
- 3) From Section – II attempt Q. No. 7 or 8, Q. No. 9 or 10 and Q. No. 11 or 12.
- 4) **Neat** diagrams must be drawn **wherever** necessary.
- 5) **Black** figures to the **right** indicate **full** marks.
- 6) Use of non-programmable scientific calculator is **allowed**.
- 7) **Assume** suitable data, **if** necessary.

SECTION – I

1. a) Explain with neat sketches how rotating magnetic field is developed when 3 phase balanced supply is given to the stator windings of a 3 phase induction motor. 6
- b) Differentiate between squirrel cage rotor and phase wound rotor of a 3 phase induction motor. 4
- c) A 50 Hz, 3 phase induction motor has P poles and is running at N-rpm. Its synchronous speed is  $N_s$  rpm. Determine the following in terms of the above
- i) Slip
- ii) Relative speed of rotating magnetic field ( $\phi_1$ ) of stator with respect to stator.
- iii) Relative speed of rotor magnetic field ( $\phi_2$ ) with respect to stator and also with respect to rotor. 6

OR

2. a) Develop the equivalent circuit of a 3 phase induction motor step by step and refer all parameter of the equivalent circuit to the stator. State any assumptions made. 8
- b) A 3 phase induction motor has starting torque of 100 percent and maximum torque of 200 percent of full load torque. Find the magnitude of slip if the motor is developing torque equal to (i) maximum torque (ii) full load torque. 8

P.T.O.



3. a) Draw and label the power flow diagram of a 3 phase induction motor. **3**
- b) State the effects of increasing rotor resistance on starting current, starting torque, maximum torque and slip of maximum torque of a 3 phase slip ring induction motor. **5**
- c) Draw the circle diagram for a 3 phase, 6 pole, 50 Hz, 400 V, star connected induction motor from the following data (line values of voltages and currents).  
 No load test : 400 V, 10 A, 1400 W  
 Short circuit test : 200 V, 55 A, 7000 W  
 The stator loss at standstill is 60% of the total copper losses and full load current is 30 A. From the circle diagram determine
- Output, efficiency and torque at full load.
  - Starting torque.
- Take current scale as 5 Amp = 1 cm. **8**
- OR
4. a) Draw the phasor diagram of a 3 phase induction motor using standard notations. **4**
- b) The following data pertains to an induction motor :
- Stator impedance =  $(1.2 + j 3.0) \Omega$   
 Rotor standstill impedance =  $(1.2 + j 2.0) \Omega$   
 No load shunt impedance =  $(12 + j 55) \Omega$   
 Supply voltage per phase = 240 V  
 Slip = 5%, Unity turn ratio between stator and rotor.  
 Determine the following :
- Equivalent load resistance
  - Stator input current
  - Input power factor
  - Mechanical power developed
  - Efficiency of motor. **12**
5. a) With the help of a neat diagram explain the operation of a direct on line starter to start a 3 phase induction motor. Derive also the relation between starting torque and full load torque in terms of starting current, full load current and slip at full load. **10**
- b) The stand still impedances of outer and inner cages of a double - cage induction motor are  $(2 + j 1.2) \Omega$  and  $(0.5 + j 3.5) \Omega$  respectively. Determine the slip at which the two cages develop equal torques. **8**

OR



6. a) Explain with the help of diagrams the construction and principle of operation of a double cage induction motor. Draw its equivalent circuit and torque - speed characteristics. **10**
- b) A squirrel cage induction motor when started by means of a star-delta starter takes 200 percent of full load line current and develops 45 percent of full load torque at starting. Calculate the starting torque and current of an auto - transformer with 80 percent tapping were employed. **8**

SECTION – II

7. a) Explain in brief the following with reference to a 3 phase induction motor :  
i) Cogging  
ii) Crawling  
iii) Noisy operation. **8**
- b) Explain plugging of a 3 phase induction motor. **4**
- c) State advantages of electric braking. **4**

OR

8. a) With the help of phasor diagrams describe the effects of injected e.m.f. in the rotor of a 3 phase induction motor. **8**
- b) Explain the principle of operation of a 3 phase induction regulator. What are its advantages over autotransformer ? **8**
9. a) Explain with double revolving field theory why a single phase induction motor is not self starting. Hence develop the torque - slip characteristics of the motor. **8**
- b) A 220 V, single phase induction motor gave the following test results :

Blocked rotor test : 120 V, 9.6 A, 460 W

No load test : 220 V, 4.6 A, 125 W.

The stator winding resistance is 1.5 ohm and during the blocked - rotor test, the starting winding is open. Determine the equivalent circuit parameters. Draw the equivalent circuits during blocked rotor and no load tests. **8**

OR

10. a) Explain with suitable sketches, the construction and working of a single phase shaded pole motor. How will you reverse the direction of rotation of this motor ? Show this with the help of a suitable diagram. **10**



- b) A 0.5 hp, 230 V, single phase induction motor, (split phase) takes a current of 4.2 A lagging the voltage by  $10^\circ$  for the auxiliary winding and a current of 6.2 A lagging the voltage by  $40^\circ$  for its main winding. Find :
- Total current and p.f. at the time of starting.
  - Total current and p.f. during running.
  - Power drawn by the main winding. 6
11. a) What problems are noticed when a d.c. series motor is connected across a a.c. supply of an equivalent voltage rating ? How these are overcome ? 6
- b) With the help of suitable diagrams explain how unidirectional torque is produced in an a.c. single phase series motor ? 4
- c) A 250 V, 50 Hz, single phase series motor runs at 2800 rpm and draws a current of 1.8 A at 0.7 p.f. lagging. The motor resistance which includes resistance of field and armature is 3.1 ohm. Find the speed and p.f. at which it would run if the supply voltage reduces to 230 V, 50 Hz, motor developing the same torque as before. Draw phasor diagrams. 8

OR

12. a) Briefly describe the construction of a fractional kW single phase series motor. Sketch its phasor diagram. Mark various emfs and voltage drops on it. State the expressions for the magnitude of various emfs induced in its windings and their frequencies. 8
- b) A 0.2 H.P, 250 V, 50 Hz universal motor has a total resistance of 30 ohm and a total reactance of 155 ohm. Using circle diagram and neglecting iron, friction and windage losses, find
- F.L. Current.
  - P.f. at full load.
  - Torque at full load if full load speed is 6000 rpm.
  - Power input at full load.
  - Efficiency of motor at full load. 10
- Take voltage scale as 20 Volt = 1 cm.  
1 H.P. = 746 watt.



**T.E. (Electrical) (Sem. – I) Examination, 2009**  
**MICROPROCESSOR FUNDAMENTALS AND APPLICATIONS**  
**(2003 Course)**

Time : 3 Hours

Max. Marks : 100

- Instructions:** 1) Answer *any three* questions from *each Section*.  
2) Answer *three* questions from *Section – I* and *three* questions from *Section – II*.  
3) Answers to the *two* Sections should be written *in separate books*.  
4) *Neat diagrams* must be drawn *wherever necessary*.  
5) Assume *suitable data, if necessary*.

SECTION – I

1. a) Draw functional block diagram of 8085 microprocessor. 8  
b) What is necessity of multiplexing ? 2  
c) Explain necessity of flags and explain flag register of 8085 microprocessor. 6

OR

2. a) What are different addressing modes of 8085 ? Explain them by giving one example each. 8  
b) Specify the contents of accumulator and carry flag when the following instructions are executed.  
MVI A, A7H  
ORA A  
RAR  
RAL 4  
c) Explain control and status signals used by 8085. 4

P.T.O.



3. a) Write an assembly language program to find largest number from array of numbers. **8**
- b) Calculate the count to obtain a 100  $\mu$ s loop delay and express the value in Hex. Assume clock frequency 2 MHz.

Label	Mnemonic	T-states	
	MVI B, Count		
UP :	NOP	4	
	NOP	4	
	DCR B	4	
	JNZ UP	10/7	<b>8</b>

OR

4. a) Write an assembly language program to add the following five data bytes stored in memory locations starting from 6000 H and display the sum.  
Data (H) : 1A, 32, 4F, 12, 27. **8**
- b) It is proposed to interface 4K RAM and 2K ROM using 3 to 8 decoder with 8085 microprocessor. Draw the scheme specifying the selected address. **8**
5. a) List various data transfer standards and explain RS - 232 in detail. **8**
- b) Draw and explain block diagram of 8251. **10**

OR

6. a) What is baud rate ? Explain synchronous and asynchronous data communication. **10**
- b) Explain command and status word format of 8251. **8**



SECTION – II

- 7. a) Explain the control word format for different modes of 8255 with example. **6**
- b) Interface 4 LED's with 8085 using Port A of 8255 PPI. Use common mode technique. Draw the interface diagram. Write program to flash alternate LED's. **10**

OR

- 8. a) Explain the input modes and display modes provided by 8279. **6**
- b) Write a program to generate a square wave of 1 KHz assuming that a 2 MHz clock is available and the 8254 reg are mapped on the I/O address space of 8085 at location C<sub>0</sub>, C<sub>1</sub>, C<sub>2</sub> and C<sub>3</sub>. Also draw and explain the interfacing scheme. **10**

- 9. a) What changes are necessary in ramp to limit the peak voltage to 7.5 V ?  
Modify the program to generate a square wave with amplitude of 5 V and 1 KHz frequency. **8**
- b) Write 8085 based program to rotate the stepper motor in full step mode clockwise for T<sub>1</sub> steps and anticlockwise for T<sub>2</sub> step. The pattern outputed for driving in full step mode with given delay subroutine is as follows :

Step	SW <sub>4</sub>	SW <sub>3</sub>	SW <sub>2</sub>	SW <sub>1</sub>	
1	0	0	1	1	
2	1	0	0	1	↓      ↑
3	1	1	0	0	Clockwise Anticlockwise
4	0	1	1	0	
1	0	0	1	1	

Use PA<sub>0</sub>, PA<sub>1</sub>, PA<sub>2</sub>, PA<sub>3</sub> of 8255 chip to operate switch S<sub>1</sub> and S<sub>4</sub>. **8**

OR



- 10. a) Explain how 8085 can be interfaced to an 8 bit A/D converter. Give specifications of the ADC used. Write a program to digitize the input waveforms and store 100 samples in external RAM. **10**
- b) With help of block diagram explain how pf of 3  $\phi$  AC balanced circuit can be measured with the help of  $\mu$  p 8085. **6**
- 11. a) What is pipe lining ? How it is achieved in 8086 ? What are its advantages ? **4**
- b) Draw and explain the pin diagram in detail of 8086. **6**
- c) Explain the concept of memory segmentation used in 8086. Enlist the segment registers in 8086. **8**

OR

- 12. a) Explain and draw the internal functional block diagram of 8086. **7**
- b) What is the role of Execution Unit in 8086 ? Explain the working of its each section. **6**
- c) What are the role of pointer and index registers in 8086 ? How are they used ? **5**

\_\_\_\_\_